

MiMA®

ARTICULATED FORKLIFT MJ20



- Lithium Battery
- Ultra High Narrow Aisle Precision
- 210 Degree Flexible Steering
- Laser Assisted Forks
- Enhanced Electric Handling
- HD Camera Display

OVERVIEW

MiMA forklifts are manufactured by MiMA Machinery, which is a subsidiary of Hefei Banyitong Science & Technology Development Co Ltd. MiMA Machinery specialises in the production of innovative material handling equipment, including electric forklifts, reach trucks, pallet trucks, and pallet stackers.

Hefei Banyitong Science & Technology Development Co Ltd was founded in 2005 and is recognised for its commitment to innovation, quality, and technological advancement in the field of material handling.

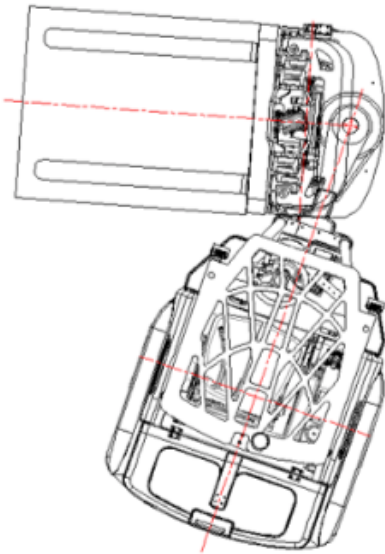

The MiMA MJ20 articulated forklift stands out for its innovative design, eco-friendly lithium-ion power, and agile 210 degree turning, making it ideal for navigating tight spaces. With zero emissions, it promotes a cleaner work environment. Advanced features like lithium battery, near-silent driving and laser assisted forks enhance both performance and operator comfort. Its compact size and efficient operation improve productivity in warehouse tasks. Companies seeking sustainable and efficient material handling solutions in confined spaces often choose the MJ20 for its combination of innovation, eco-friendliness, and enhanced performance.

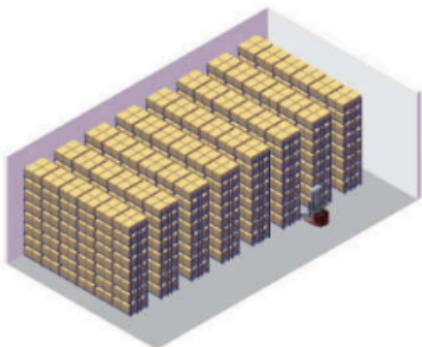

Articulated Forklift

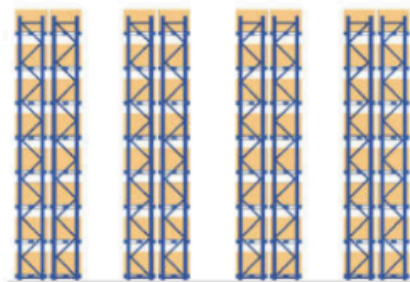

Rack Height > 10m > Up to 12.5m.

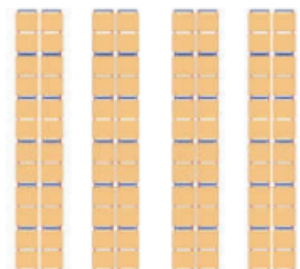

Aisle Width 1.9m

Precise Handling



Lithium Battery



The MiMA MJ20 features electric fingertip or traditional lever controls, empowering operators to manoeuvre with precision and finesse.

The MiMA MJ20 forklift comes equipped with a cutting-edge lithium-ion battery, delivering longer runtimes, ultra fast and opportune charging.

Laser Assisted Forks



The MiMA MJ20 forklift is equipped with state-of-the-art laser-assisted forks, ensuring seamless alignment with heavy loads and pallets every time.

HD Camera Display



See more, do more! MiMA MJ20 HD camera display, operators gain unparalleled visibility and control. Navigate even the busiest warehouses with confidence, thanks to crystal-clear visuals that enhance safety and productivity.

LCD Display



The MiMA MJ20 forklift boasts an intuitive LCD display, providing real-time insights into battery status, error codes, and operational settings. Stay in control of your workflow and optimize performance with this user-friendly interface.

Mast Heights

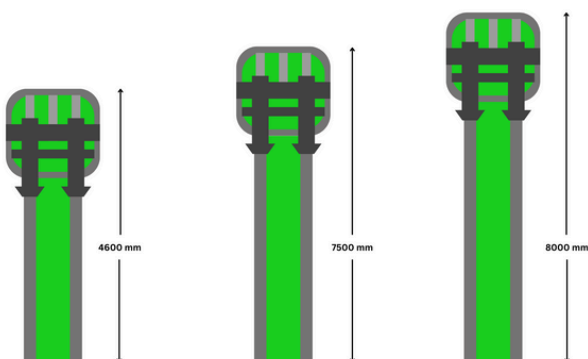

Choose from multiple mast heights:

- 4600 mm
- 5700 mm
- 7500 mm
- 8000 mm

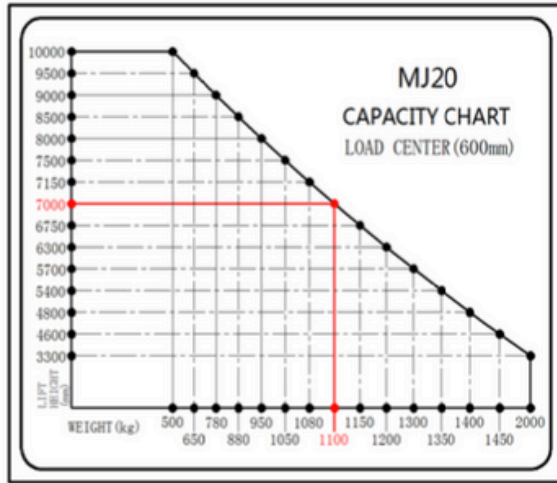
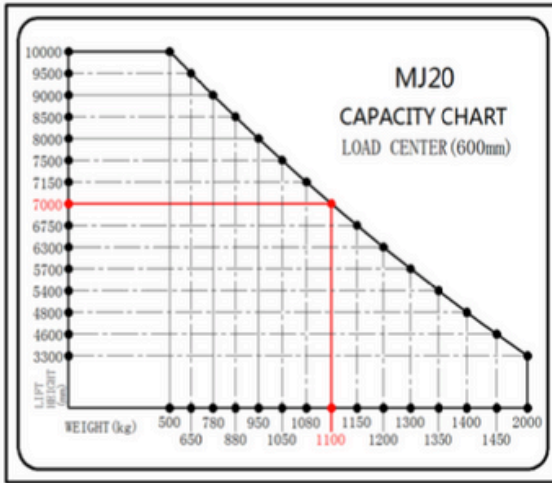

Mast Specification:

Triplex Full Free Mast	MJ20 / MJ20H										
Model	MJ	20-46	20-48	20-54	20-57	20-63	20-67	20-70	20-71	20-75	20-80
Lift height	h3(mm)	4620	4820	5420	5720	6320	6770	7020	7170	7520	8020
Mast extended height with load backrest	h4(mm)	5800	6000	6600	6900	7500	7950	8200	8350	8700	9200
Mast closed height	h1(mm)	2818	2885	3085	3185	3385	3485	3568	3618	3734	3900
Free lift height	h2(mm)	1134	1200	1400	1500	1700	1950	2034	2084	2202	2368
Triplex Full Free Mast	MJ20 / MJ20H										
Model	MJ	20-85	20-90	20-95	20-100	20-105	20-108	20-110	20-115	20-120	20-125
Lift height	h3(mm)	8520	9020	9520	10020	10520	10820	11020	11520	12020	12520
Mast extended height with load backrest	h4(mm)	9700	10200	10700	11200	11700	12000	12200	12700	13200	13700
Mast closed height	h1(mm)	4067	4234	4400	4567	4734	4834	4900	5067	5234	5400
Free lift height	h2(mm)	2534	2700	2868	3034	3200	3300	3368	3534	3700	3868

